

## PARTS

- A** gables - plywood - (2)  $\frac{3}{4}$ " x 15" x  $30\frac{1}{4}$ "
- B** bottom - plywood - (1)  $\frac{3}{4}$ " x  $14\frac{3}{4}$ " x  $22\frac{5}{8}$ "
- C** shelf - plywood - (1)  $\frac{3}{4}$ " x  $14\frac{3}{4}$ " x  $22\frac{5}{8}$ "
- D** stringers - plywood - (2)  $\frac{3}{4}$ " x  $2\frac{1}{2}$ " x  $22\frac{5}{8}$ "
- E** front wine bottle supports - solid wood - (1 blank) 1" x 5" x  $22\frac{1}{4}$ " (see drawing)
- F** back wine bottle supports - solid wood - (2) 1" x 2" x  $22\frac{1}{4}$ " (see drawing)
- G** top - plywood - (1)  $\frac{3}{4}$ " x 16" x 24"
- H** top trim - solid wood - (1) 1" x  $1\frac{1}{2}$ " x cut to fit
- I** back panel - plywood - (1)  $\frac{1}{4}$ " x cut to fit
- J** doors - (2)

Machine rabbets and dados into gables to accept bottom panel, shelf, stringers and back panel.

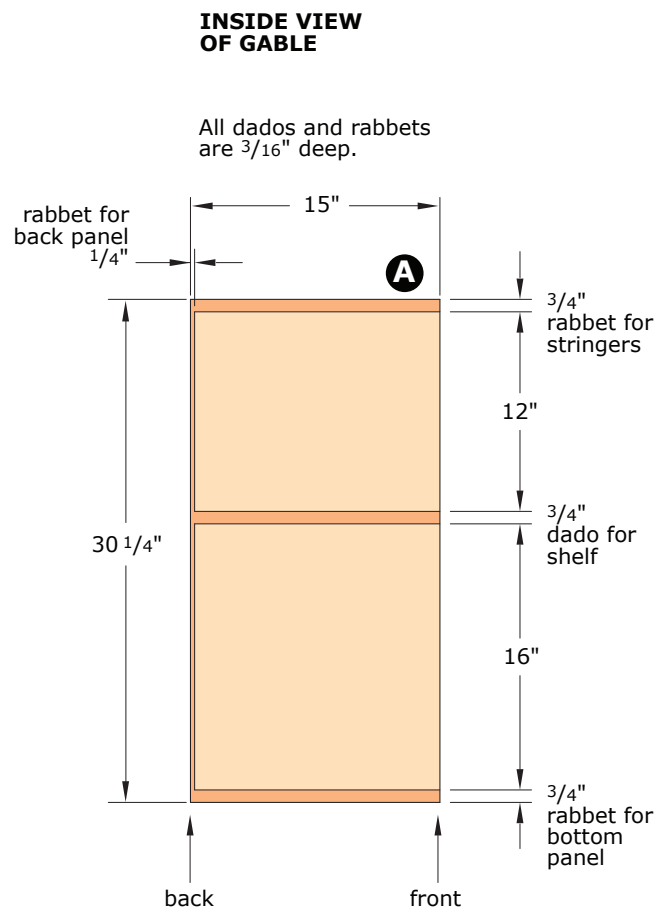
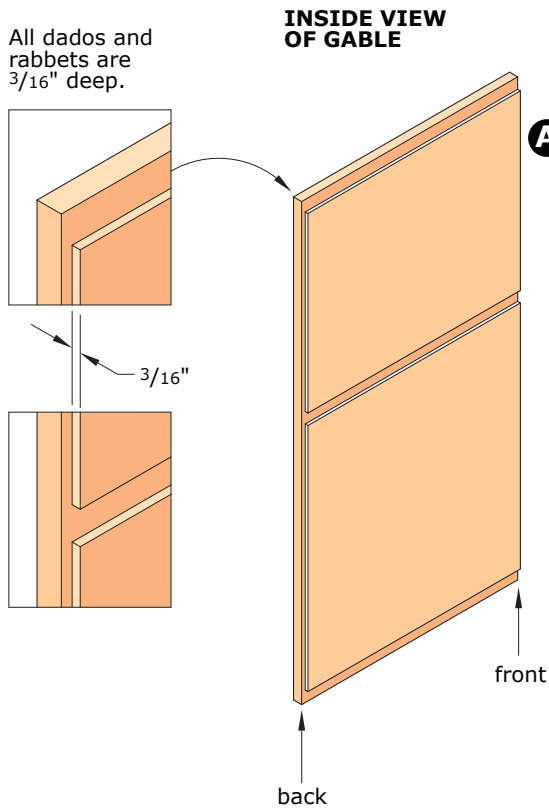

Sand the interior surfaces of all parts and assemble the six parts with glue.

Be sure to leave the 1/4" back rabbet clear for the 1/4" back panel.

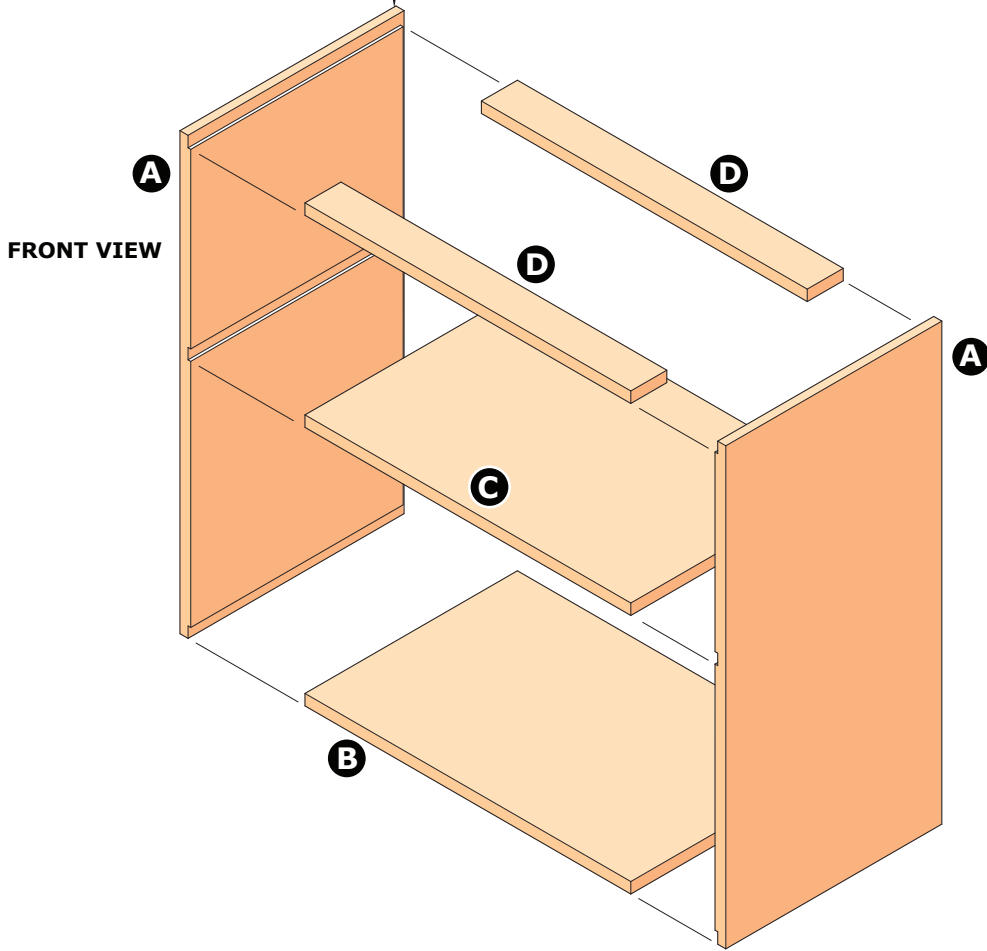

Position the back stringer 1/4" from the backs of the gables to make room for the 1/4" back panel.

Position the shelf, bottom panel and front stringer, flush with the fronts of the gables.

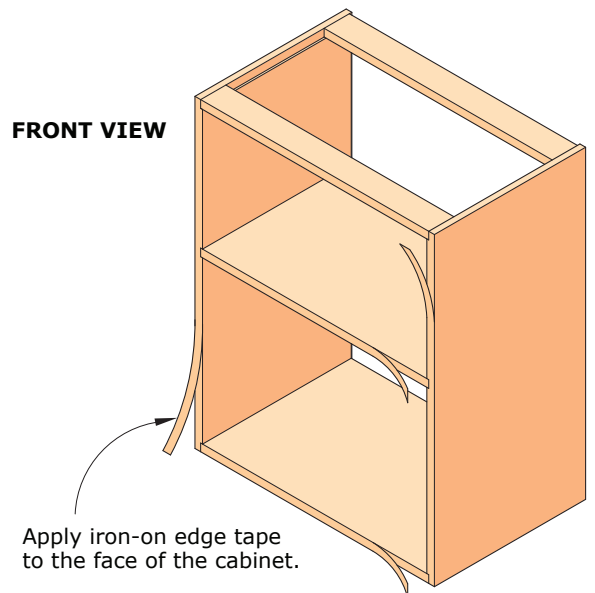
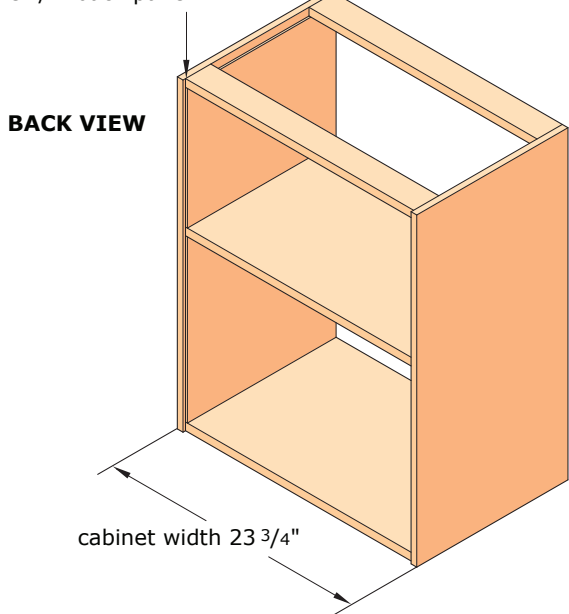

## WINE BOTTLE SUPPORTS

blank for front wine bottle supports

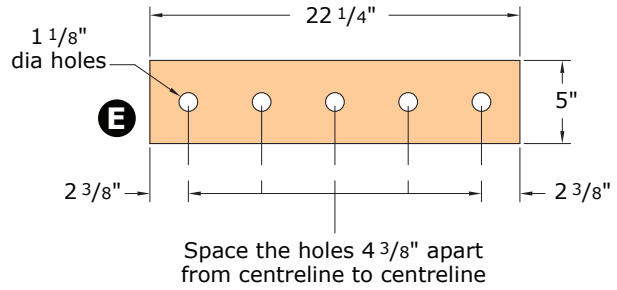
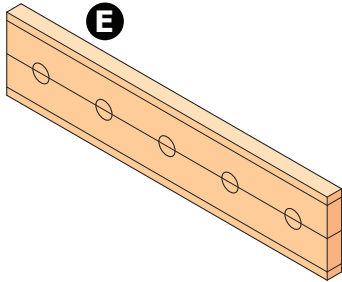

Rip 1/2" off the top and bottom of the blank so that the blank is 4" high.  
Rip the blank in half through the centres of the holes so that both pieces are 2" high.

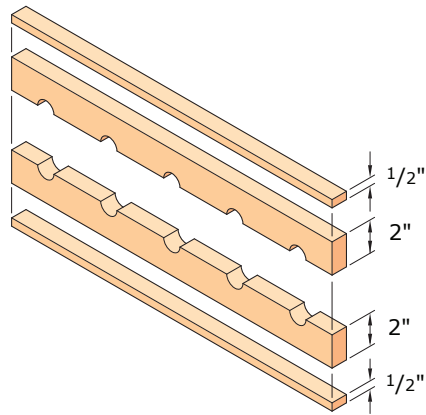

back wine bottle supports

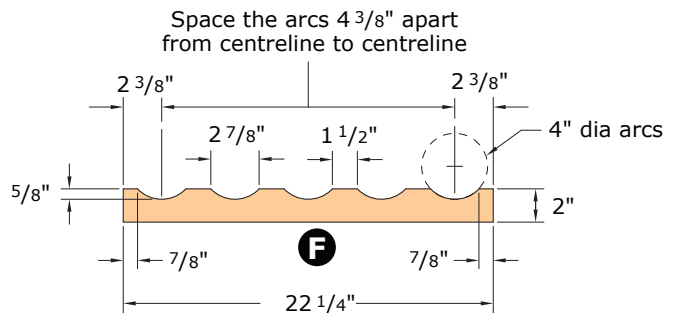
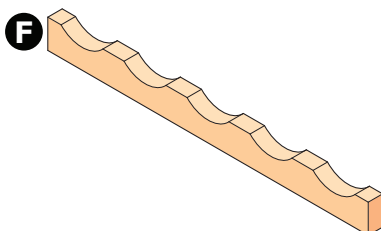

**FRONT VIEW**

Temporarily install the upper wine bottle supports with "L" brackets.

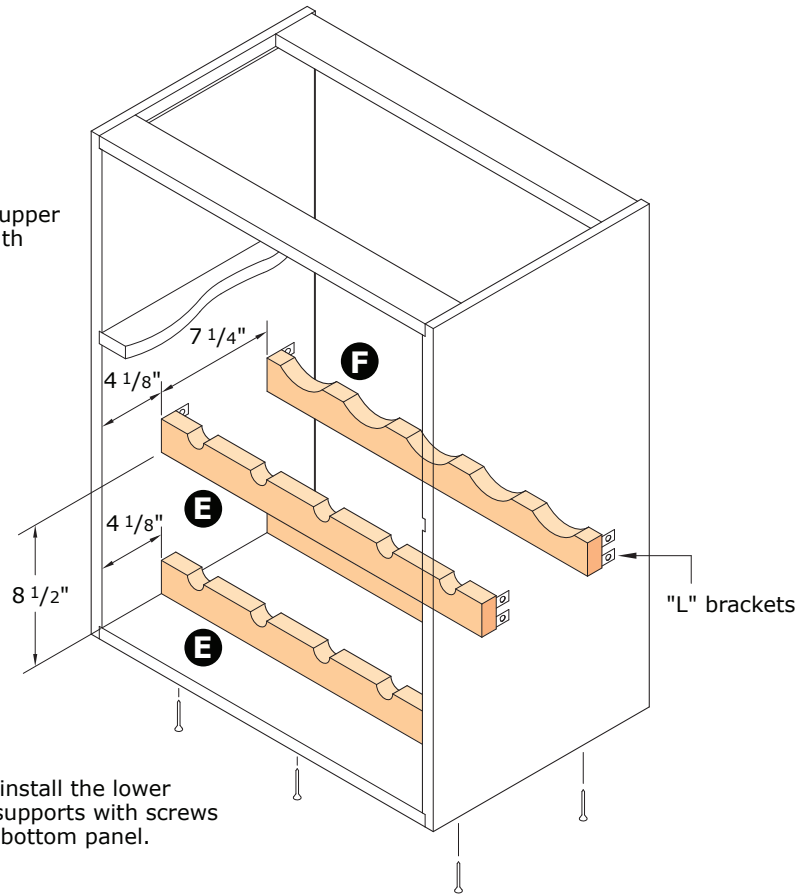

Temporarily install the lower wine bottle supports with screws through the bottom panel.

Now remove all four supports.

**TOP PANEL**

Cut and mitre the trim.  
Glue and clamp trim to top piece.

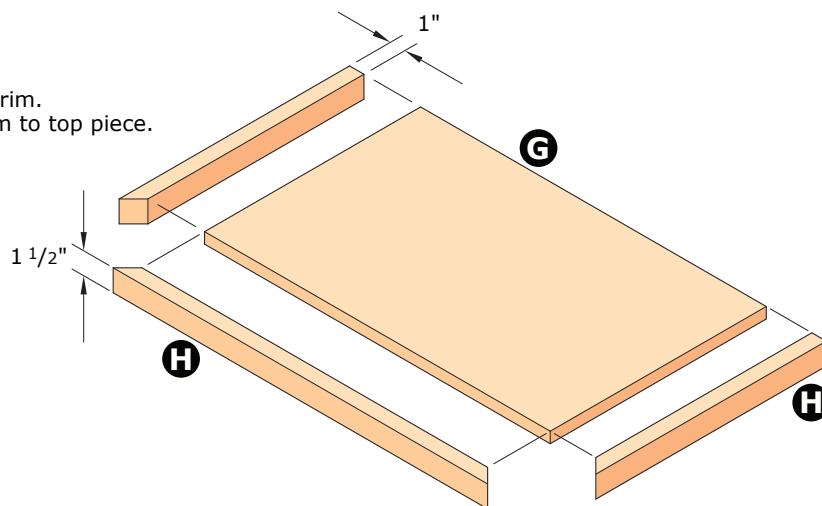

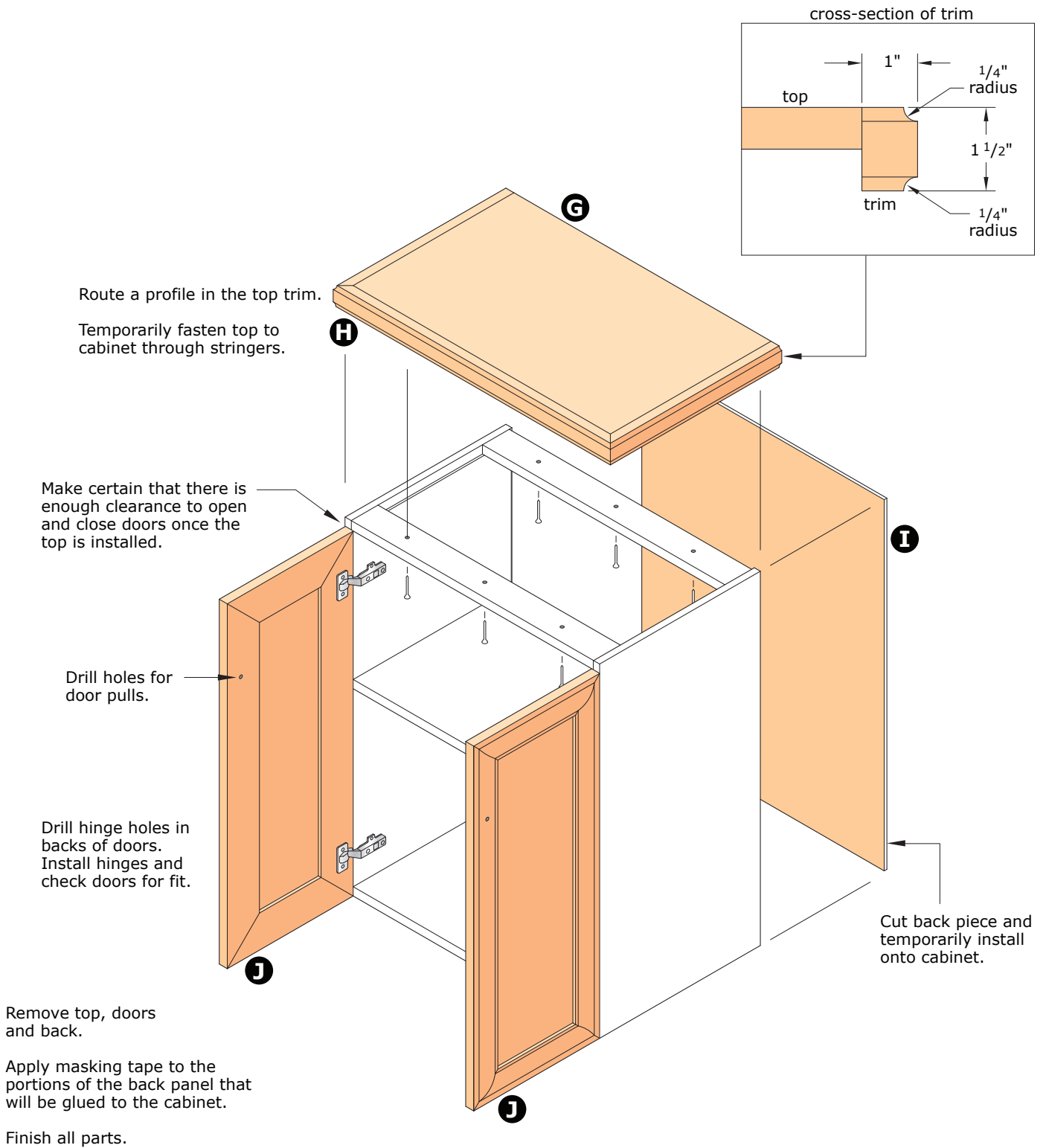

Re-assemble all parts and add castors and stemware holders.

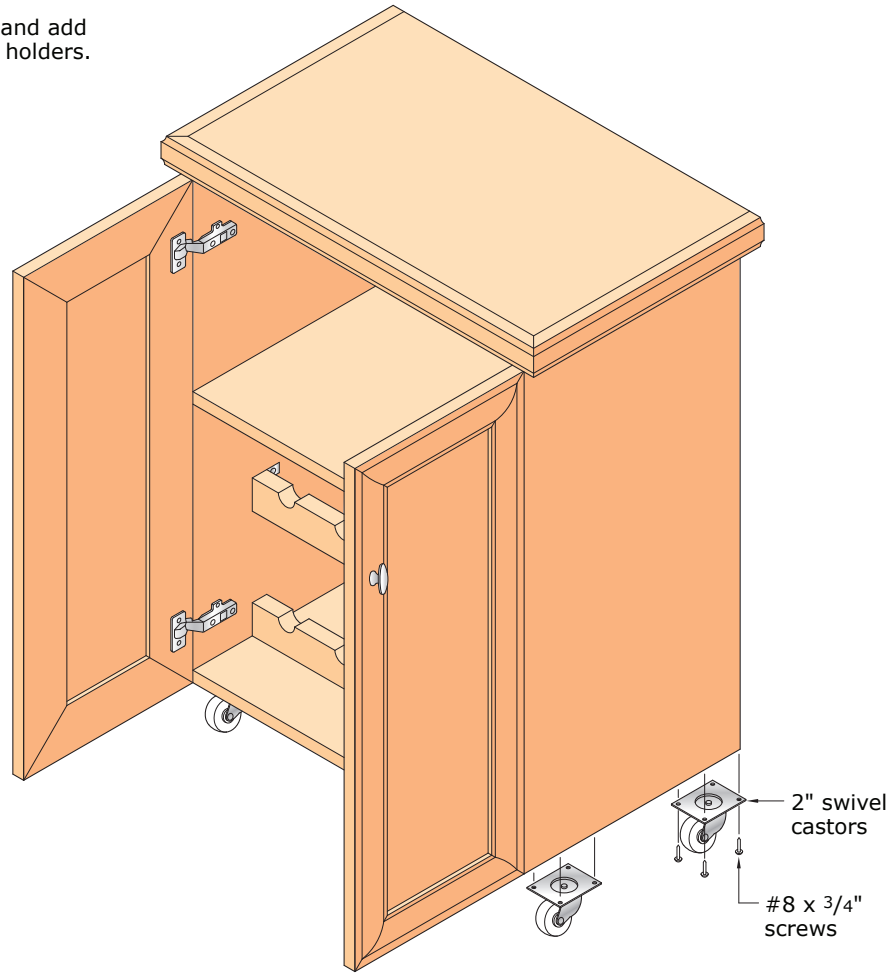

**FRONT INSIDE VIEW**

